



The UL-HZ2518 Hazard Tape is designed to ensure visibility of obstacles in escape routes for compliance with NFPA 101 Life Safety Code (NFPA 101) and International Fire Code (IFC). The Hazard Tape will be effective in all light conditions including failure of the main lighting.

COMPLIANCE

UL Listed and NFPA 101 and IFC compliant. Can be used in Performance Solutions to meet the requirements of any performance based building codes.

Brightness - High visibility in light or dark conditions meets UL 1994.

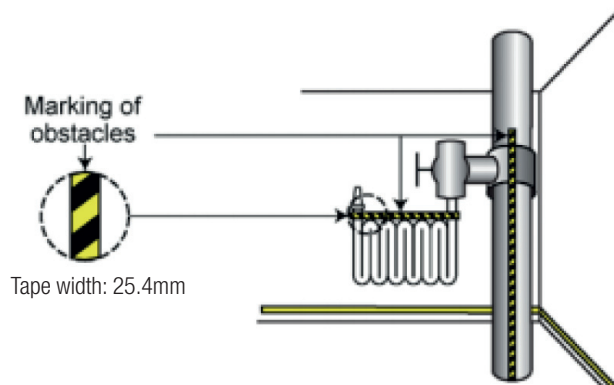

SUPPLY

The photoluminescent hazard tape is available in rolls of 18 metres.

COMPOSITION

Manufactured using high quality vinyl, the UL-HZ2518 Hazard Tape has a premium integrated adhesive which provides a superior bond to a variety of surfaces.

INSTALLATION

Installation is a simple process using pre-fitted release tape.

UL-HZ2518 25.4mm wide x 18m roll

Contact

Ecoglo International Limited

Email: info@ecoglo.com **Web:** www.ecoglo.com